

Globe Valves

铸钢产品

Cast steel products

CLASS 150 GLOBE VALVE

Standards:

结构长度	Face to Face Dimensions:	ANSI B16.10
法兰尺寸	End Flange Dimensions:	ANSI B16.5
设计标准	Basic Design:	BS 1873
检验标准	Test Standart:	API 598

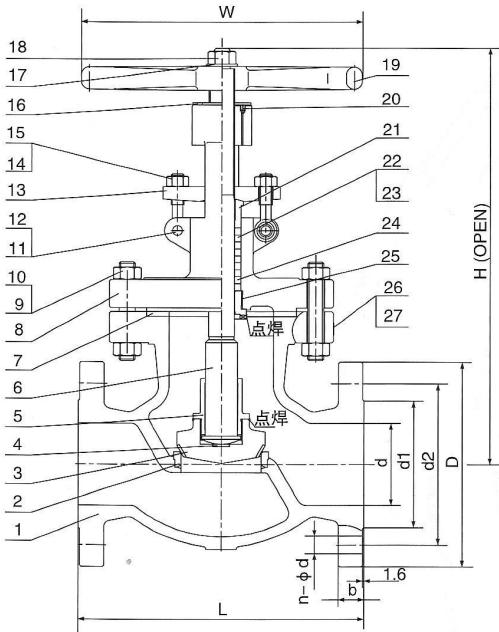

Material List

No	Part Name	Qty.	Material
1	阀体 Body	1	A216 WCB
2	阀座 Seat	1	A105+HF
3	闸瓣 Disc	1	A216 WCB+F6
4	止推垫 Thrust Plate	1	A276 430
5	阀瓣盖 Disc Cover	1	A276 410
6	阀杆 Stem	1	A182 F6
7	垫片 Gasket	1	304+Flexible Graphite
8	阀盖 Bonnet	1	A216 WCB
9	螺柱 Bolt		A193 B7
10	螺母 Nut		A194 2H
11	销轴 Pin	2	A29 1035
12	开口销 Split Pin	2	A570 Gr.A
13	压板 Gland Flange	1	A216 WCB
14	螺栓 Eye Bolt	2	A193 B7
15	螺母 Nut	2	A194 2H
16	阀母 Stem Nut	1	D-2
17	垫片 Gasket	1	A276 410
18	螺母 Eye Nut	1	A29 1035
19	手轮 Handwheel	1	60-40-18
20	螺钉 Screw	1	A29 1035
21	压套 Gland	1	A276 410
22	填料 Packing	2	Stainless Steel Wire
23	填料 Packing	4-5	With Flexible Graphite
24	隔环 Distance Ring	1	A276 410
25	密封座 Back Seat	1	A276 410
26	铆钉 Rivet	2	304
27	铭牌 Name Plate	1	304

DIMENSIONS AND WEIGHTS

NPS	in	2	2-1/2	3	4	5	6	8	10	12	14	16	18	20	24
d	mm	51	64	76	102	127	152	203	254	305	337	387	438	489	591
L-L1 (BF-BW)	in	8.00	8.50	9.50	11.50	14.00	16.00	19.50	24.50	27.50	31.00	36.00	38.5	38.5	51.00
	mm	203	216	241	292	356	406	495	622	698	787	914	978	978	1295
L2 (RTJ)	in	8.50	9.00	10.00	12.00	14.50	16.50	20.00	25.00	28.00	31.50	36.50	39.00	39.00	51.5
	mm	216	229	254	305	368	419	508	635	711	800	927	990.5	990.5	1308
d1	in	3.62	4.13	5.00	6.18	7.32	8.50	10.63	12.76	15.00	16.26	18.50	20.98	23.00	27.24
	mm	92	105	127	157	186	216	270	324	381	413	470	533	584	692
d2	in	4.75	5.50	6.00	7.50	8.50	9.50	11.75	14.25	17.00	18.75	21.25	22.75	25.00	29.50
	mm	120.5	139.5	152.5	190.5	216	241.5	298.5	362	432	476	540	578	635	749.5
D	in	6.00	7.00	7.50	9.00	10.00	11.00	13.50	16.00	19.00	21.00	23.50	25.00	27.50	32.00
	mm	152	178	190	229	254	279	343	406	483	533	597	635	699	813
b	in	0.75	0.88	0.94	0.94	0.94	1.00	1.13	1.19	1.25	1.38	1.44	1.56	1.69	1.88
	mm	19	22.5	24	24	24	26	29	31	32	35	37	40	43	48
n-φd	in	4-0.75	4-0.75	4-0.75	8-0.75	8-0.87	8-0.87	8-0.87	12-1.00	12-1.00	12-1.12	16-1.12	16-1.25	20-1.25	20-1.38
	mm	4-19	4-19	4-19	8-19	8-22	8-22	8-22	12-25	12-25	12-29	16-29	16-32	20-32	20-35
H (open)	in	13.43	14.45	14.76	19.02	21.14	20.35	23.23	29.69	37.05	38.03	42.72	48.20	54.10	60.00
	mm	341	367	375	483	537	517	590	754	941	966	1085	1225	1375	1525
W	in	7.87	9.84	9.84	11.81	11.81	13.78	15.75	17.72	25.20	25.20	18.00	18.00	22.00	22.00
	mm	200	250	250	300	300	350	400	450	640	640	460*	460*	560*	560*
WT (Kg)	RF	22	29	42	64	77	105	154	288	507	617	810	1060	1360	2010
	BW	19	25	34	49	65	82	131	249	430	580	763	950	1150	1860

* Manual gear operator is recommended.

CLASS 300 GLOBE VALVE

Standards:

结构长度	Face to Face Dimensions:	ANSI B16.10
法兰尺寸	End Flange Dimensions:	ANSI B16.5
设计标准	Basic Design:	BS 1873
检验标准	Test Standart:	API 598

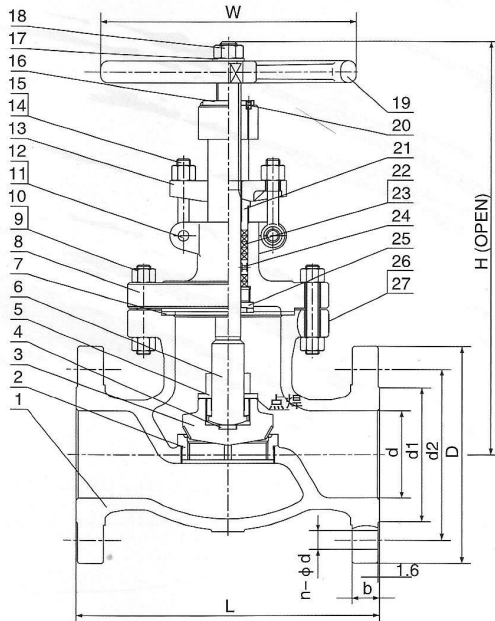

Material List

No	Part Name	Qty.	Material
1	阀体 Body	1	A216 WCB
2	阀座 Seat	1	A105+HF
3	闸瓣 Disc	1	A216 WCB+F6
4	止推垫 Thrust Plate	1	A276 430
5	阀瓣盖 Disc Cover	1	A276 410
6	阀杆 Stem	1	A182 F6
7	垫片 Gasket	1	304+Flexible Graphite
8	阀盖 Bonnet	1	A216 WCB
9	螺栓 Bolt		A193 B7
10	螺母 Nut		A194 2H
11	销轴 Pin	2	A29 1035
12	开口销 Split Pin	2	A570 Gr.A
13	压板 Gland Flange	1	A216 WCB
14	螺栓 Eye Bolt	2	A193 B7
15	螺母 Nut	2	A194 2H
16	阀母 Stem Nut	1	D-2
17	垫片 Gasket	1	A276 410
18	螺母 Eye Nut	1	A29 1035
19	手轮 Handwheel	1	60-40-18
20	螺钉 Screw	1	A29 1035
21	压套 Gland	1	A276 410
22	填料 Packing	2	Stainless Steel Wire
23	填料 Packing	4-5	With Flexible Graphite
24	隔环 Distance Ring	1	A276 410
25	密封座 Back Seat	1	A276 410
26	铆钉 Rivet	2	304
27	铭牌 Name Plate	1	304

DIMENSIONS AND WEIGHTS

NPS		2	2-1/2	3	4	5	6	8	10	12	14	16
d	mm	51	64	76	102	127	152	203	254	305	337	387
L-L1	in	10.50	11.50	12.50	14.00	15.75	17.50	22.00	24.50	28.00	33.00	34.00
(BF-BW)	mm	267	292	318	356	400	444	559	622	711	838	864
L2	in	11.12	12.12	13.12	14.62	16.37	18.12	22.62	25.12	28.62	33.62	34.62
(RTJ)	mm	283	308	333	371	416	460	575	638	727	854	879
d1	in	3.62	4.13	5.00	6.18	7.32	8.50	10.63	12.76	15.00	16.26	18.50
	mm	92	105	127	157	186	216	270	324	381	413	470
d2	in	5.00	5.87	6.63	7.87	9.25	10.63	13.00	15.25	17.75	20.25	22.50
	mm	127	149	168.5	200	235	270	330	387.5	451	514.5	571.5
D	in	6.50	7.50	8.25	10.00	11.00	12.50	15.00	17.50	20.50	23.00	25.50
	mm	165	190	210	254	279	318	381	445	521	584	648
b	in	0.88	1.00	1.14	1.26	1.38	1.46	1.65	1.89	2.01	2.13	2.28
	mm	23	26	29	32	35	37	42	48	51	54	58
n-φd	in	8-0.75	8-0.87	8-0.87	8-0.87	8-0.87	12-0.87	12-1.00	16-1.13	16-1.25	20-1.25	20-1.38
	mm	8-19	8-22	8-22	8-22	8-22	12-22	12-25	16-29	16-32	20-32	20-35
H	in	13.74	14.80	16.93	19.13	22.05	24.33	36.89	37.36	39.17	42	46.7
(open)	mm	349	376	430	486	560	618	937	949	995	1066	1185
W	in	7.87	9.84	9.84	13.78	15.75	17.22	22.05	25.20	18.11	22.00	22.00
	mm	200	250	250	350	400	450	560	640	460*	560*	560*
WT	RF	31	43	57	86	130	168	280	385	724	780	980
(Kg)	BW	26	38	44	68	110	138	228	329	618	655	835

* Manual gear operator is recommended.

CLASS 600 GLOBE VALVE

Standards:

结构长度	Face to Face Dimensions:	ANSI B16.10
法兰尺寸	End Flange Dimensions:	ANSI B16.5
设计标准	Basic Design:	BS 1873
检验标准	Test Standart:	API 598

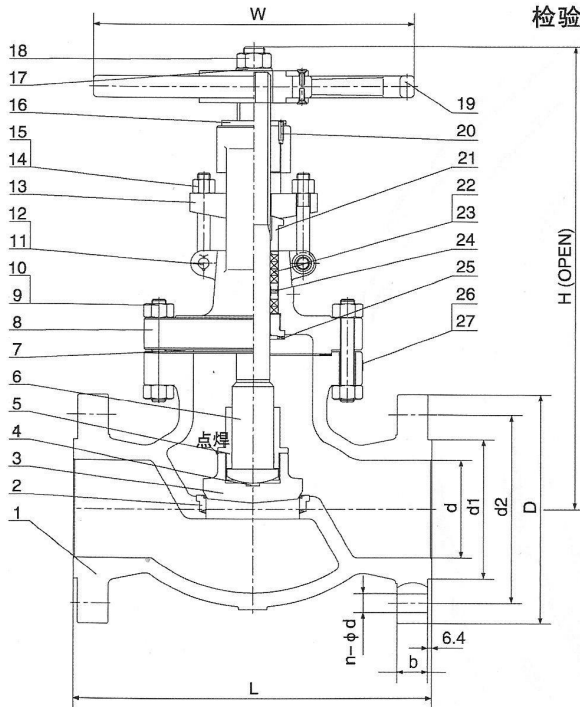

Material List

No	Part Name	Qty.	Material
1	阀体 Body	1	A216 WCB
2	阀座 Seat	1	A105+HF
3	闸瓣 Disc	1	A216 WCB+F6
4	止推垫 Thrust Plate	1	A276 430
5	阀瓣盖 Disc Cover	1	A276 410
6	阀杆 Stem	1	A182 F6
7	垫片 Gasket	1	304+Flexible Graphite
8	阀盖 Bonnet	1	A216 WCB
9	螺栓 Bolt		A193 B7
10	螺母 Nut		A194 2H
11	销轴 Pin	2	A29 1035
12	开口销 Split Pin	2	A570 Gr.A
13	压板 Gland Flange	1	A216 WCB
14	螺栓 Eye Bolt	2	A193 B7
15	螺母 Nut	2	A194 2H
16	阀母 Stem Nut	1	D-2
17	垫片 Gasket	1	A276 410
18	螺母 Eye Nut	1	A29 1035
19	手轮 Handwheel	1	60-40-18
20	螺钉 Screw	1	A29 1035
21	压套 Gland	1	A276 410
22	填料 Packing	2	Stainless Steel Wire
23	填料 Packing	4-5	With Flexible Graphite
24	隔环 Distance Ring	1	A276 410
25	密封座 Back Seat	1	A276 410
26	铆钉 Rivet	2	304
27	铭牌 Name Plate	1	304

DIMENSIONS AND WEIGHTS

NPS	in	2	2-1/2	3	4	6	8	10	12
d	mm	51	64	76	102	152	200	248	298
L-L1	in	11.50	13.00	14.00	17.00	22.00	26.00	31.00	33.00
(BF-BW)	mm	292	330	356	432	559	660	787	838
L2	in	11.62	13.12	14.12	17.12	22.12	26.12	31.12	33.12
(RTJ)	mm	295	333	359	435	562	664	791	841
d1	in	3.62	3.94	5.00	6.18	8.50	10.63	12.76	15.00
	mm	92	100	127	157	216	270	324	381
d2	in	5.00	5.87	6.62	8.50	11.50	13.75	17.00	19.25
	mm	127	149	168	216	292	349	432	489
D	in	6.50	7.50	8.25	10.75	14.00	16.50	20.00	22.00
	mm	165	190	210	273	356	419	508	559
b	in	1.00	1.14	1.26	1.50	1.89	2.20	2.52	2.64
	mm	26	29	32	38	48	56	64	67
n-φd	in	8-0.75	8-0.87	8-0.87	8-1.00	12-1.13	12-1.25	16-1.38	20-1.38
	mm	8-19	8-22	8-22	8-25	12-29	12-32	16-35	20-35
H	in	16.73	19.76	20.51	24.41	34.88	36.69	40.94	50.39
(open)	mm	425	502	521	620	886	932	1040	1280
W	in	9.84	11.81	13.78	17.72	22.05	18.11	24.02	29.92
	mm	250	300	350	450	560	460*	610*	760*
WT	RF	39	58	73	120	327	482	700	900
(Kg)	BW	33	48	61	95	261	385	588	795

* Manual gear operator is recommended.

CLASS 900 GLOBE VALVE

Standards:

结构长度	Face to Face Dimensions:	ANSI B16.10
法兰尺寸	End Flange Dimensions:	ANSI B16.5
设计标准	Basic Design:	BS 1873
检验标准	Test Standart:	API 598

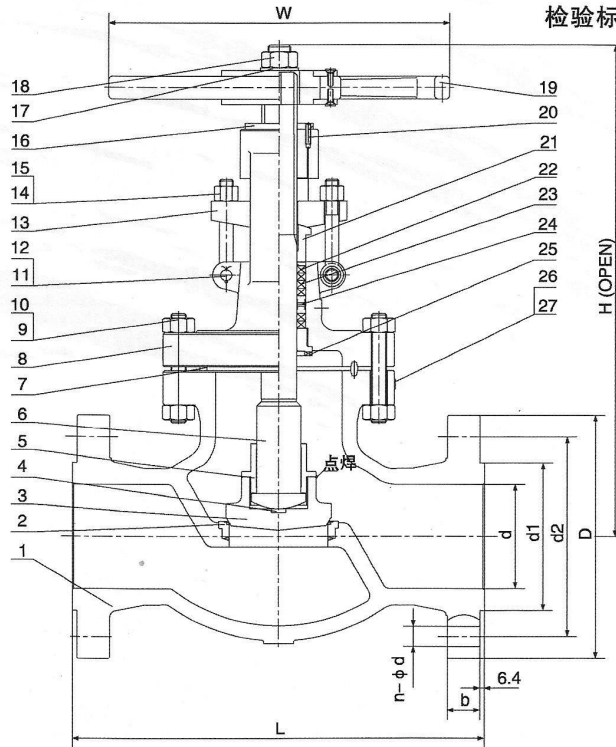

Material List

No	Part Name	Qty.	Material
1	阀体 Body	1	A216 WCB
2	阀座 Seat	1	A105+HF
3	闸瓣 Disc	1	A216 WCB+F6
4	止推垫 Thrust Plate	1	A276 430
5	阀瓣盖 Disc Cover	1	A276 410
6	阀杆 Stem	1	A182 F6
7	垫片 Gasket	1	A29 1008
8	阀盖 Bonnet	1	A216 WCB
9	螺栓 Bolt		A193 B7
10	螺母 Nut		A194 2H
11	销轴 Pin	2	A29 1035
12	开口销 Split Pin	2	A570 Gr.A
13	压板 Gland Flange	1	A216 WCB
14	螺栓 Eye Bolt	2	A193 B7
15	螺母 Nut	2	A194 2H
16	阀母 Stem Nut	1	D-2
17	垫片 Gasket	1	A276 410
18	螺母 Eye Nut	1	A29 1035
19	手轮 Handwheel	1	60-40-18
20	螺钉 Screw	1	A29 1035
21	压套 Gland	1	A276 410
22	填料 Packing	2	Stainless Steel Wire
23	填料 Packing	4-5	With Flexible Graphite
24	隔环 Distance Ring	1	A276 410
25	密封座 Back Seat	1	A276 410
26	铆钉 Rivet	2	304
27	铭牌 Name Plate	1	304

DIMENSIONS AND WEIGHTS

NPS		2	2-1/2	3	4	6	8	10
d	in	47	57	73	98	146	190	238
	mm							
L-L1	in	14.50	16.50	15.00	18.00	24.00	29.00	33.00
(BF-BW)	mm	368	419	381	457	610	737	838
L2	in	14.62	16.62	15.12	18.12	24.12	29.12	33.12
(RTJ)	mm	371	422	384	460	613	740	841
d1	in	3.62	4.13	5.00	6.18	8.50	10.63	12.75
	mm	92	105	127	157	216	270	324
d2	in	6.50	7.50	7.50	9.25	12.50	15.50	18.50
	mm	165.1	190.5	190.5	234.9	317.5	393.7	469.9
D	in	8.50	9.62	9.50	11.50	15.00	18.50	21.50
	mm	216	244	241	292	381	470	545
b	in	1.50	1.63	1.50	1.75	2.20	2.50	2.75
	mm	38.5	41.5	38.5	44.5	56	63.5	70
n-φd	in	8-1.00	8-1.13	8-1.00	8-1.25	12-1.25	12-1.50	16-1.50
	mm	8-26	8-29	8-26	8-32	12-32	12-39	16-39
H	in	18.82	19.76	24.17	31.06	34.88	36.69	40.94
(open)	mm	478	502	614	789	886	932	1040
W	in	13.78	15.75	17.72	22.05	18.11	24.02	24.02
	mm	350	400	450	560	460*	610*	610*
WT	RF	100	118	131	218	452	710	870
(Kg)	BW	75	94	105	185	340	630	690

* Manual gear operator is recommended.

CLASS 1500 GLOBE VALVE

Standards:

结构长度	Face to Face Dimensions:	ANSI B16.10
法兰尺寸	End Flange Dimensions:	ANSI B16.5
设计标准	Basic Design:	API 6D&BS1868
检验标准	Test Standart:	API 598

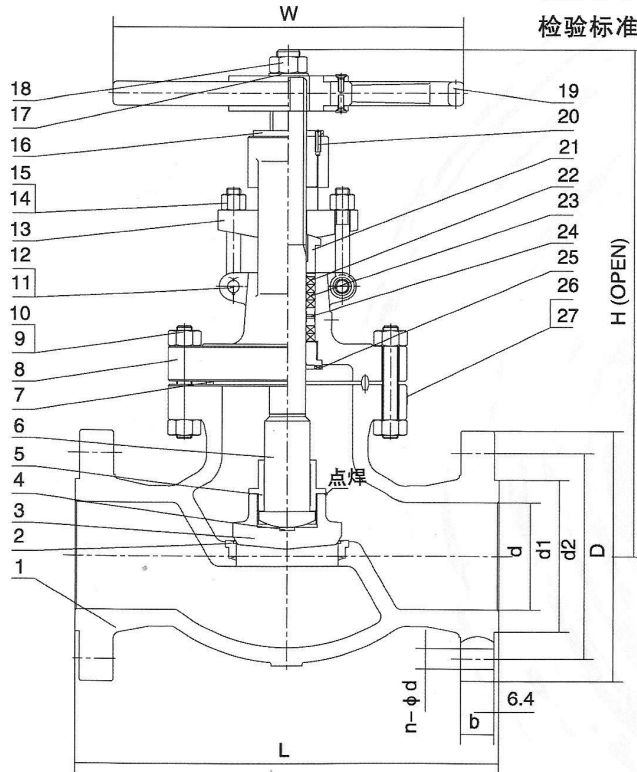

Material List

No	Part Name	Qty.	Material
1	阀体 Body	1	A216 WCB
2	阀座 Seat	1	A105+HF
3	闸瓣 Disc	1	A216 WCB+F6
4	止推垫 Thrust Plate	1	A276 430
5	阀瓣盖 Disc Cover	1	A276 410
6	阀杆 Stem	1	A182 F6
7	垫片 Gasket	1	A29 1008
8	阀盖 Bonnet	1	A216 WCB
9	螺柱 Bolt		A193 B7
10	螺母 Nut		A194 2H
11	销轴 Pin	2	A29 1035
12	开口销 Split Pin	2	A570 Gr.A
13	压板 Gland Flange	1	A216 WCB
14	螺栓 Eye Bolt	2	A193 B7
15	螺母 Nut	2	A194 2H
16	阀母 Stem Nut	1	D-2
17	垫片 Gasket	1	A276 410
18	螺母 Eye Nut	1	A29 1035
19	手轮 Handwheel	1	60-40-18
20	螺钉 Screw	1	A29 1035
21	压套 Gland	1	A276 410
22	填料 Packing	2	Stainless Steel Wire
23	填料 Packing	4-5	With Flexible Graphite
24	隔环 Distance Ring	1	A276 410
25	密封座 Back Seat	1	A276 410
26	铆钉 Rivet	2	304
27	铭牌 Name Plate	1	304

DIMENSIONS AND WEIGHTS

NPS		2	2-1/2	3	4	6	8
d	in	47	57	70	92	136	178
	mm						
L-L1	in	14.50	16.50	18.50	21.50	27.75	32.75
(BF-BW)	mm	368	419	470	546	705	832
L2	in	14.62	16.62	18.62	21.62	28.00	33.13
(RTJ)	mm	371	422	473	549	711	841
d1	in	3.62	4.13	5.00	6.18	8.50	10.63
	mm	92	105	127	157	216	270
d2	in	6.50	7.50	8.00	9.50	12.50	15.50
	mm	165.1	190.5	203.2	241.3	317.5	393.7
D	in	8.50	9.62	10.50	12.25	15.50	19.00
	mm	216	244	267	311	394	483
b	in	1.50	1.63	1.89	2.13	3.25	3.63
	mm	38.5	41.5	48.0	54.0	83.0	92.9
n-φd	in	8-1.00	8-1.13	8-1.25	8-1.38	12-1.50	12-1.75
	mm	8-26	8-29	8-32	8-35	12-39	12-45
H	in	23.31	25.98	27.24	35.71	39.96	45.08
(open)	mm	592	660	692	907	1015	1145
W	in	13.78	15.75	17.72	18.11	24.02	24.02
	mm	350	400	450	460	610	610
WT	RF	112	141	228	336	822	720
(Kg)	BW	84	115	183	277	715	615

* Manual gear operator is recommended.